

HTI DALI 315 DIM

HALOTRONIC | – Dimmer modules



Product family features

- DALI trailing-edge phase dimmer
- Dimming of high voltage halogen and incandescent lamps
- Dimming of many common dimmable line voltage LED lamps
- Dimming of electronic transformers
- Standby power consumption: < 0.5 W
- DALI/Touch DIM control signal
- Short-circuit protection, overload protection, overtemperature protection: electronically reversible
- RI suppression: to EN 55015 (A1: 2007)
- Line harmonics according to EN 61000-3-2
- Safety: to EN 61347
- Immunity according to EN 61547
- Device fits also for special applications where dimming below 1 % is required

Product datasheet

Technical data

Electrical data

Lamp wattage	3...315 W
Nominal voltage	220...240 V
Nominal output voltage	220...240 V
Mains frequency	50 Hz
System wattage	315.00 W

Dimensions & weight

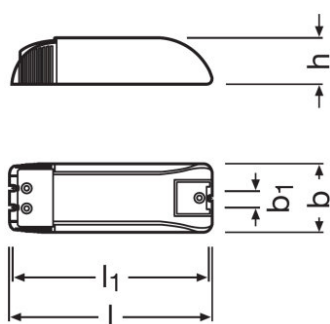

Length	153.0 mm
Width	54.0 mm
Height	36.0 mm
Mounting hole spacing, width	15.0 mm
Mounting hole spacing, length	146.0 mm
Product weight	137.00 g

Temperatures & operating conditions

Ambient temperature range	0...+45 °C
---------------------------	------------

Additional product data

Design / version	Compact with cable clamp
------------------	--------------------------

Capabilities

Dimming method	Trailing-edge dimmer
Dimming interface	Phase cut-off
Overheating protection	Automatic reversible
Max. cable length to lamp/LED module	100 m
Dimmable	Yes

Product datasheet

Dimming range	0.1...100 % ¹⁾
----------------------	---------------------------

¹⁾ Depends on the lamp type (please see www.osram.com/dim)

Certificates & standards

Type of protection	IP20
---------------------------	------



Logistical data

Commodity code	850440909000
-----------------------	--------------

Equipment / Accessories

- Suitable for all OSRAM HALOTRONIC and ET-PARROT ECGs
- Suitable for all dimmable OSRAM line voltage LED lamps

Download Data

File	
	Installation/Operation notice 341073_HTi DALI 315 DIM Installation Guide
	CAD data 3-dim 320673_HTM 150
	CAD data 3-dim 320679_HTM 150

Logistical Data

Product code	Product description	Packaging unit (Pieces/Unit)	Dimensions (length x width x height)	Volume	Gross weight
4008321957344	HTI DALI 315 DIM	Shipping carton box 25	292 mm x 300 mm x 260 mm	22.78 dm ³	4368.00 g

The mentioned product code describes the smallest quantity unit which can be ordered. One shipping unit can contain one or more single products. When placing an order, for the quantity please enter single or multiples of a shipping unit.

Disclaimer

Subject to change without notice. Errors and omission excepted. Always make sure to use the most recent release.